

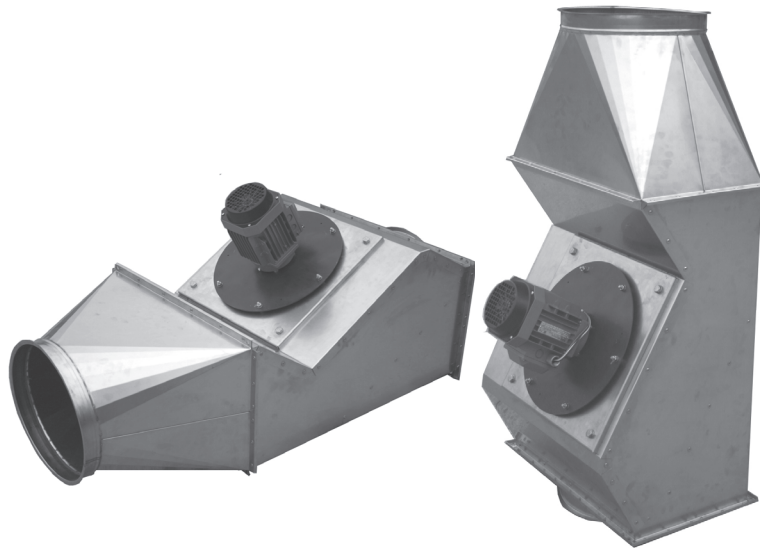





# IPVB 300-500 EC

## inline power venter



READ AND SAVE THESE INSTRUCTIONS!

	<b>Product information</b>	<b>Chapters 1 + 2</b>
	<b>Mechanical installation</b>	<b>Chapter 3</b>
	<b>Electrical installation</b>	<b>Chapter 4</b>
	<b>Start up and configuration</b>	<b>Chapter 5</b>
	<b>Maintenance and troubleshooting</b>	<b>Chapter 6</b>

USA

CAN

**Job name:** \_\_\_\_\_



**Installer:** \_\_\_\_\_

**Installation date:** \_\_\_\_\_

**Distributor contact information:**  
ENERVEX Inc. • T: 800.255.2923  
info@enervex.com • www.enervex.com



# Contents

	<b>1. Product information</b>	
	1.1 Function .....	3
	1.2 Components .....	3
	1.3 Shipping .....	4
	1.4 Listings .....	4
	1.5 Warranty .....	4
	<b>2. Specifications</b>	
	2.1 Dimensions .....	5
	<b>3. Mechanical installation</b>	
	3.1 General .....	6
	3.2 Positioning .....	6
	3.3 Drain installation .....	7
	3.4 Mounting of power venter .....	7
	3.5 Location/connections .....	7
	3.6 Vertical installation .....	8
	3.7 Horizontal installation .....	8
	3.8 Installation of rain guard .....	9
	<b>4. Electrical installation</b>	
	4.1 General .....	9
	4.2 Wiring diagram – IPVB 300-350 .....	10
	4.3 Wiring Diagram – IPVB 400-500 .....	10
	4.4 Configuring and connecting a Variable Frequency Drive (VFD) .....	11
	4.5 Installing a Proven Draft Switch .....	11
	4.5 Installation of stack probe for PDS function .....	12
	4.6 Checking and changing rotation of IPVB 300, 350, 400, and 500 .....	12
	<b>5. Startup and configuration</b>	
	5.1 General .....	13
	5.2 System testing .....	13
	5.3 Adjusting fan speed .....	13
	5.4 Testing safety system .....	13
	<b>6. Maintenance and troubleshooting</b>	
	6.1 General .....	14
	6.2 Preparing the Power Venter for Cleaning .....	14
	6.3 Troubleshooting .....	15

## Symbol legend

The following terms are used throughout this manual to bring attention to the presence of potential hazards or to important information concerning the product.



### DANGER

Indicates an imminent hazardous situation which, if not avoided, will result in death, serious injury or substantial property damage.



### CAUTION

Indicates an imminent hazardous situation which, if not avoided, may result in personal injury or property damage.



**TO REDUCE THE RISK OF FIRE, ELECTRICAL SHOCK OR INJURY TO PERSONS, OBSERVE THE FOLLOWING:**

# 1. Product information

## 1.1 Function

**Use** The **exodraft** IPVB Power Venter is intended for use as a true in-line draft inducer. It can be installed in-line in the vertical or horizontal section of a chimney or stack. It is specifically designed for applications where reliable and efficient operation, low noise level, low energy consumption, variable speed and compact design are critical.

The IPVB is for use with condensing and non-condensing appliances at flue gas temperatures of 575 °F (302 °C) for continuous operation.

Typical uses are mechanical venting of gas-fired or oil-fired boilers and water heaters. The IPVB is for indoor or outdoor installation where ambient temperatures are in the range of -40 °F to 122 °F (-40 °C to 50 °C).

**Construction** The IPVB Power Venter is an efficient, high-temperature ventilator with backward-inclined impeller. The ventilator housing is made of stainless steel and equipped with an energy-efficient, totally enclosed, variable speed motor, which is mounted outside the air stream. The design is a Type B, Spark Resistant Construction. The motor and impeller is a complete assembly (drive unit) that can be removed from the fan housing without removing the fan from the stack system. The stack connections are of the flanged connection type and fit most commercial pre-fabricated chimney systems. The fan is typically installed hung from ceiling mounting brackets to support the weight. The IPVB model is approved for temperatures up to 575 °F (302 °C).

The housing is made of 316L stainless steel. The impeller is of the backward inclined type made of cast aluminum. Commercial grade, totally enclosed (TEFC), variable speed, Class A insulated motor with sealed and permanently lubricated bearings. Thermal overload protection.

**Restrictions** The IPVB Power Venter should only be used with appliances operating on Natural Gas, LP-Gas/Butane or fuel oil (#2 through #6). It should never be used with incinerators, incinerating toilets or solid-fuel burning equipment. The temperature of the flue gases going through the Power Venter should not exceed 575 °F (302 °C).

## 1.2 Components

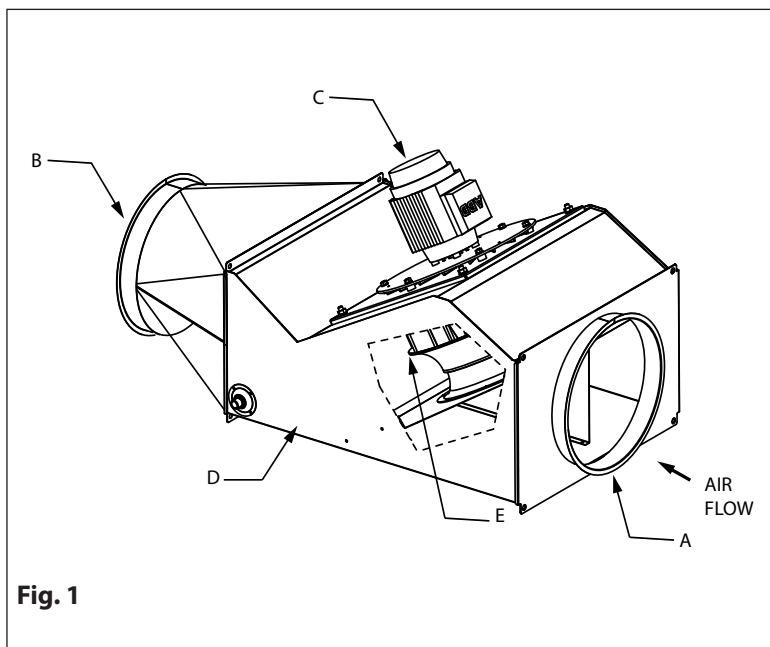

- A. Inlet
- B. Outlet
- C. Motor
- D. Housing
- E. Impeller

### 1.3 Shipping

The IPVB is shipped on a pallet covered by a cardboard box.

#### **Standard packing list**

The IPVB is shipped with a drain installation kit.

If other components are shipped, these will appear as separate items on the shipping packing list.

### 1.4 Listings

This product is listed to UL 378, Standard for Draft Equipment and CSA CAN2-B255-M81, Standard for Mechanical Flue Gas Exhausters, for temperatures up to 575°F (302°C).

### 1.5 Warranty

**Complete warranty conditions are available at [www.enervex.com](http://www.enervex.com) or request a copy at: [info@enervex.com](mailto:info@enervex.com) or at tel.: 1-800.255.2923.**

---

# 2. Specifications

## 2.1 Dimensions

exodraft In-line Fan Model		IPVB300EC42-21	IPVB350EC42-21	IPVB400EC42-21	IPVB500EC42-21
Fan Type		Centrifugal Impeller (B-wheel)			
Motor Type		Permanent Magnet (BLDC)			
Voltage	VAC	3 x 208-240	3 x 208-240	3 x 208-240 / 3 x 400-480	3 x 208-240 / 3 x 400-480
Frequency (Max)	Hz	146	146	146	146
Amperage	Amps	3.3	3.3	6.6 / 3.8	9.0 / 5.2
Motor	Output HP	1.1	1.1	2.0	3.0
	kW	0.81	0.81	1.5	2.2
Max. RPM		1740			
Duct Connection (Nominal)	in	12	14	16	20
	mm	300	350	400	500
Dimensions	A in	19.4	22.5	26.5	29.6
	mm	492	572	672	752
	B in	28.7	32.8	37.9	44.0
	mm	730	833	963	1118
	C in	14.3	15.9	18.2	22.5
	mm	363	403	463	572
	D in	12.0	14.0	16.0	20.0
	mm	306	356	406	508
	E in	10.6	12.2	14.2	15.7
	mm	270	310	360	400
	F in	7.2	8.0	9.1	11.3
	mm	182	202	232	286
	G in	15.5	15.4	15.8	19.8
	mm	393	392	402	502
	H in	21.8	24.8	26.5	30.2
	mm	553	630	674	766
J in	1.8	1.8	1.8	1.8	
mm	46	46	46	46	
L in	46.1	50.1	55.6	65.6	
mm	1170	1272	1412	1667	
W in	mm	21.2	24.4	28.3	31.5
	mm	539	619	7719	799
Weight	lbs	68	79	114	154
	kg	31	36	51.5	70
Max. Temperature		575 °F (302 °C) Continuous			

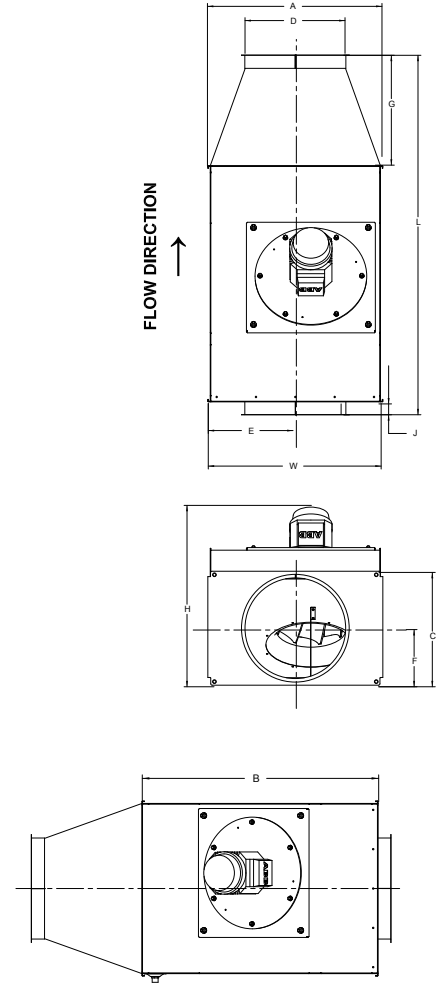

### Capacity:

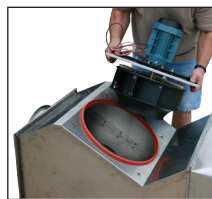
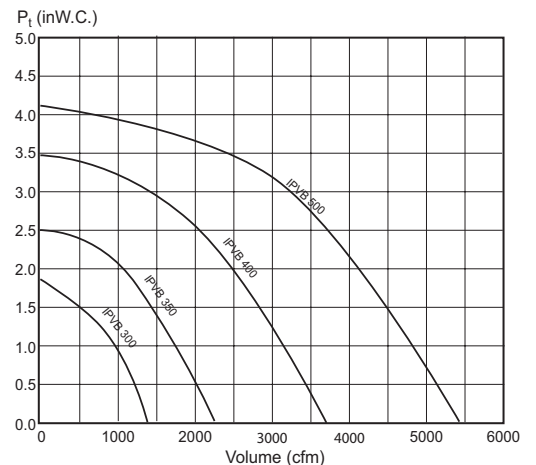

Removal of drive unit

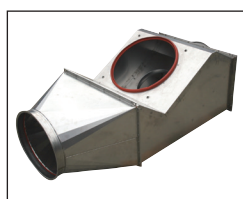

Fan without drive unit

**NOTE**  
The capacity data is tested in accordance with ISO Standard 5801: Industrial fans performance testing using standardized airways.



## 3. Mechanical installation

### 3.1 General



#### WARNING

Failure to install, maintain and/or operate the exodraft IPVB Power Venter in accordance with the manufacturer's instructions may result in conditions which can produce bodily injury and property damage.

The IPVB must be installed by a qualified installer in accordance with these instructions and all local codes, or in their absence, with the latest edition of The National Fuel Gas Code (NFPA54/ANSI223.1), NFPA 211, NFPA 31 or Canada CAN/CSA-B149.1-05 National Gas and Propane Installation Code when applicable. The IPVB must be mounted so the clearance to combustibles is at least 18 inches.

Preferably, the IPVB should be installed as close to the termination as possible. It can also be installed near the outlet of a heating appliance in the breeching itself. In addition, it can be used for sidewall vented applications where it discharges through a wall. A drain is provided with the IPVB to be installed by the user.

The IPVB is for indoor and outdoor installation. Unless installed adjacent to the wall it is discharging through, the chimney material used on the discharge side must be airtight/pressure rated. Traditional gas vent (B-vent) is not considered pressure rated or airtight. The vent pipe must be installed and supported according to the chimney manufacturer's instructions and/or in accordance with NFPA54, NFPA211 and Canada CAN/CSA-B149.1-05. The IPVB collars fit most commonly available vents and stacks.

### 3.2 Positioning

Acceptable fan positions are shown below in fig. 2. If mounted horizontally, we recommend that the motor be positioned to the side as shown in fig. 2, position B.

**The IPVB must be mounted to provide clear and easy access to the motor and impeller assembly.**

#### NOTE

**If the IPVB is mounted in position B or C, a drain must be installed as described in Section 3.3.**

**\*If the IPVB is oriented as shown in position C, the resulting axial load on the bearings may shorten the life of the motor.**



#### WARNING

Never install the power venter so the motor points down. This will shorten the life. The minimum clearance to combustibles is 18 inches.

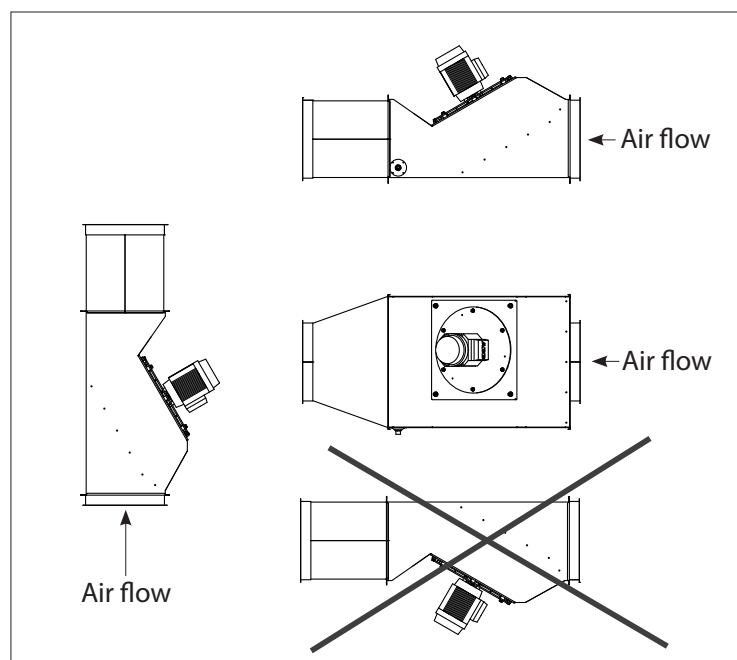
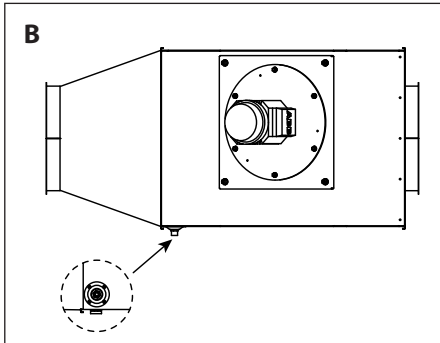

Fig. 2

### 3.3 Drain installation

Install the provided drain if the IPVB is mounted in position B. The drain should be installed near the outlet of the fan and oriented so it points toward the ground.



To install the drain:

1. Use the drain as a template to drill (4) 1/8" holes in each corner.
2. Use the (4) provided rivets to fasten the drain to the fan housing.
3. Using the fitting as a guide, drill a 1/2" hole through the housing to open the drain.

Fig. 3

### 3.4 Mounting of power venter

The IPVB has (4) 0.413" diameter mounting holes on each end of the fan. Threaded rod or steel hangers should run through these holes to hang the fan from the ceiling or other support.

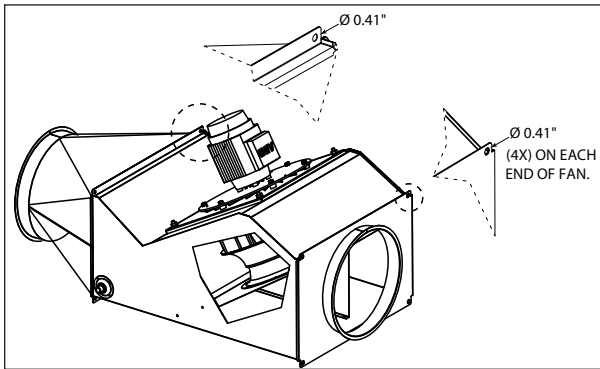

Fig. 4

### 3.5 Location/connections

Follow the recommendations by the vent or stack manufacturer. The power venter should be located at least (3) times the vent diameter from any elbow or tee.

A set of v-bands are shipped with the fan for connection to the stack.

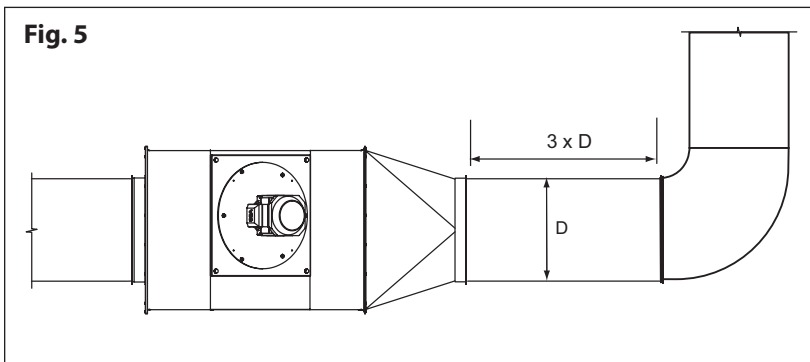
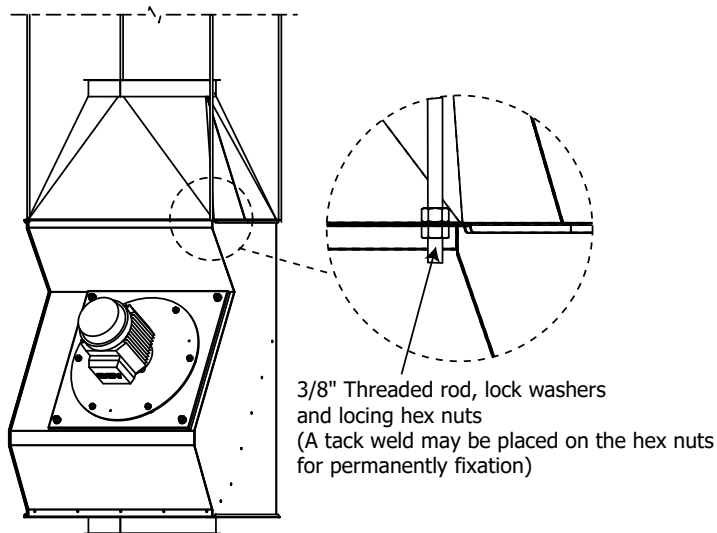

Fig. 5

### 3.6 Vertical installation

To mount the IPVB vertically, suspend the power venter with threaded rod. Once the position of the fan and rods is finalized, hang 4 pieces of threaded rod through the mounting holes of the fan as shown in fig. 6. (On back side of fan, run threaded rod through both top and bottom mounting holes.) Once the power venter is leveled, secure the rod with lock washers and locking hex nuts. (A tack weld may be placed on the hex nuts for permanent fixation).

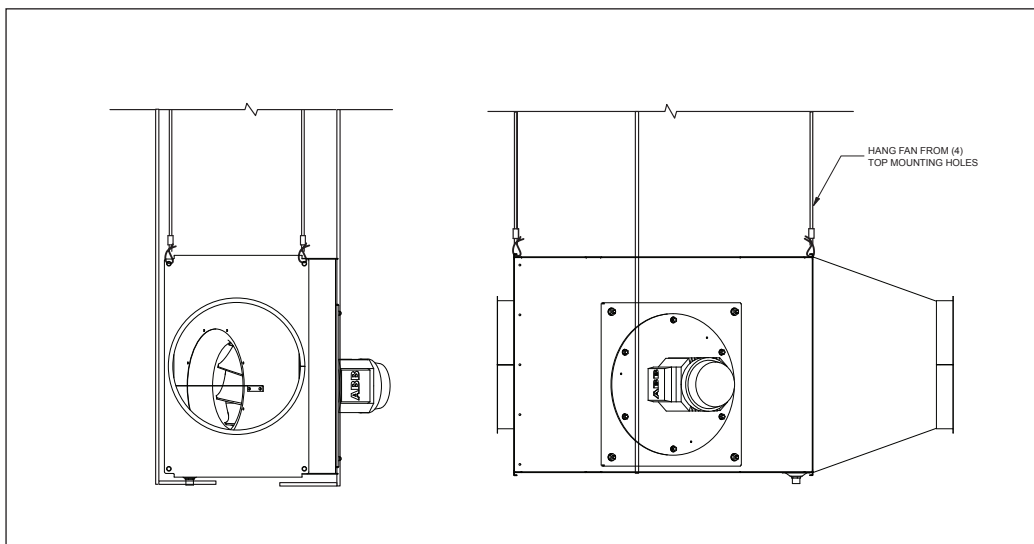

**Fig. 6**

### 3.7 Horizontal installation

To mount the IPVB horizontally, suspend the power venter with threaded rod or steel hangers. It may be necessary to cross brace the fan from end to end to prevent side sway. Ensure the fan is level before permanently securing.

L-Brackets are installed for additional support and stability of the fan. Neoprene strips (or similar) should be placed on the brackets to dampen vibration noise. Do not attach them to the fan itself.



**Fig. 7**



### 3.8 Installation of rain guard

#### For outdoor installations

If the motor is installed in vertical position and/or exposed to heavy rain a Rain Guard is required (fig. A). Center the rain guard around the motor. Orient the rain guard in a manner that will minimize water ingress, and verify that you can access the motor.

Mount the rain guard, with the sheet metal screws. They are included with the shipment (fig. B). Add a bead of silicone to the mounting flange before securing it with sheet metal screws.

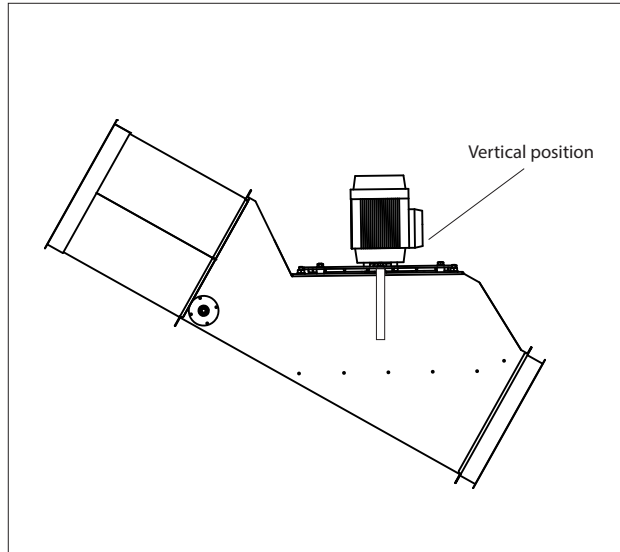

**Fig. A** - If the motor is installed in vertical position a Rain Guard is required.

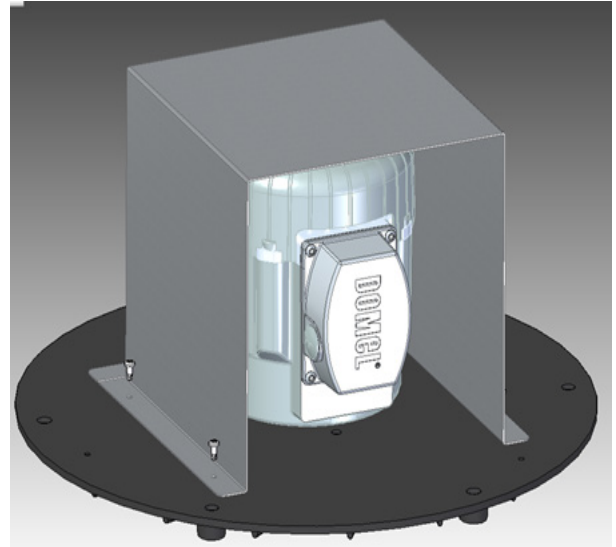

**Fig. B** - Mount the rain guard, with the sheet metal screws.

## ⚡ 4. Electrical installation

### 4.1 General



#### Danger

**Turn off electrical power before servicing. Contact with live electric components can cause shock or death.**



#### Notice

**If any of the original wire supplied with the system must be replaced, use similar wire of the same temperature rating. Otherwise, insulation may melt or degrade, exposing bare wire.**

All wiring must be in compliance with the local codes or in their absence, the National Electric Code, NFPA70. All wiring should be appropriate Class 1 wiring as follows: installed in rigid metal conduit, intermediate metal conduit, rigid non-metallic conduit, electrical metallic tubing, or be otherwise suitably protected from physical damage.

**exodraft** IPVB models operate at different voltages, please pay attention to the wiring details. IPVB 300 and 350 operates at 3 x 208-240 VAC while IPVB 400 and 500 can operate at 3 x 208-240 VAC or 3 x 400-480 VAC. This is indicated by the terminal wire configuration in the motor junction box. See Section 4.3 and 4.4.

## 4.2 Wiring diagram – IPVB 300-350

IPVB 300 and 350 can operate at 3x208-240 V AC 146 Hz (Max).

The motor wiring terminals shown in fig. 9 shows default jumper positions for 3x208-230 V AC operation.

Verify power supply voltage and motor terminal configuration **before** connection to fan.

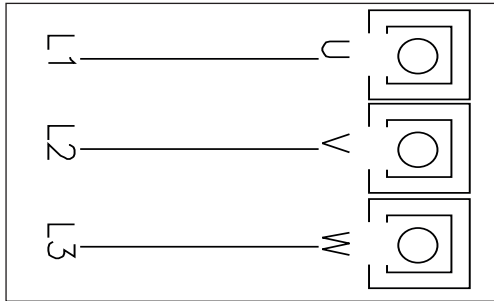

Fig. 9

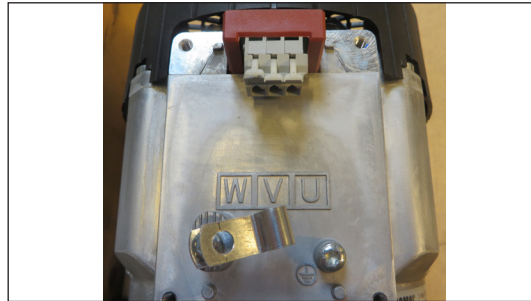

Fig. 10

## 4.3 Wiring Diagram – IPVB 400-500

IPVB 400-500 can operate at either 3x208-240 V AC 146 Hz (default) or 3 x 400-480 V AC 146 Hz based on the configuration of the terminals in the motor junction box.

The motor wiring terminals shown in fig. 11 shows default jumper positions for 3x208-240 V AC operation. If the application requires 3x400-480 V AC operation, the jumper positions must be changed according to fig. 12.

Verify power supply voltage and motor terminal configuration **before** connection to fan.

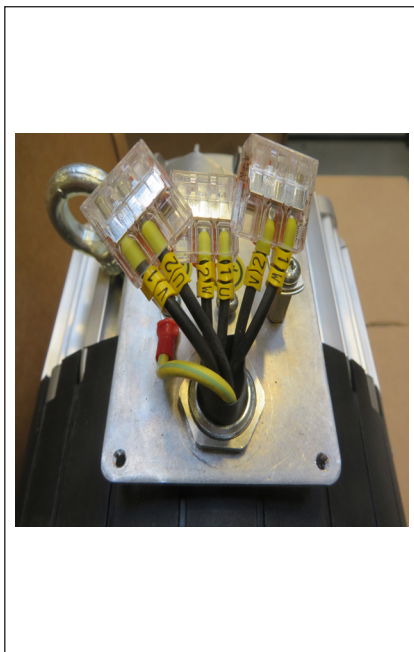

Fig. 11

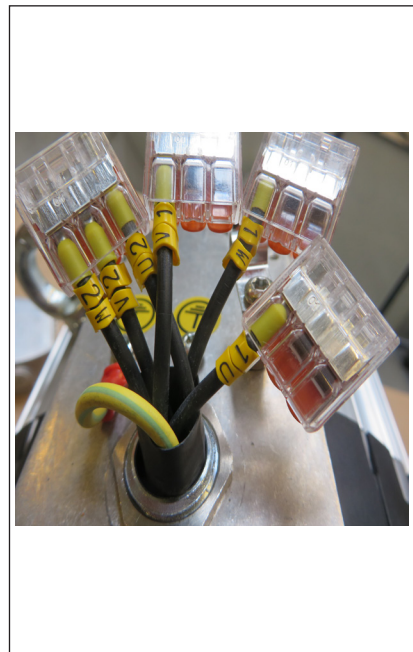

Fig. 12

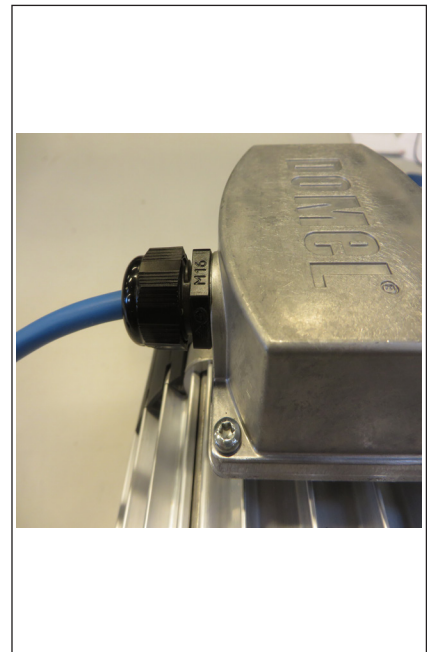

Fig. 13

Power Venter and motor specifications can be found under *Section 2.1 Dimensions and Capacities*. The power venter is equipped with a variable speed motor.

Fig. 13 shows strain relief M16

#### 4.4 Configuring and connecting a Variable Frequency Drive (VFD)

The VFD must be configured according to the data found on the type label on the motor. When editing the maximum current value for the motor, please be sure to have a maximum of 125 % of the rated current (Motor Full Load Amperes). See the table below for the correct value.

<b>exodraft</b> In-line Fan Model	IPVB300EC	IPVB350EC	IPVB400EC	IPVB500EC
Voltage [V AC]	3 x 208-240	3 x 208-240	3 x 208-240 / 3 x 400-480	3 x 208-240 / 3 x 400-480
Maximum frequency [Hz]	146	146	146	146
Power [hp]	1.1	1.1	2.0	3.0
Rated Current [A]	3.3	3.3	6.6 / 3.8	9.0 / 5.2
Maximum current (125% of motor FLA) [A]	4.12	4.12	8.25 / 4.75	11.25 / 6.5



#### Notice

**Only use EnerveX EDrive model MSC VFD's together with IPVB 300-500EC fans.**

Fig. 14 shows a typical wiring diagram utilizing a variable frequency drive (adjusting the speed is possible). After wiring, make sure the motor is rotating in the proper direction. This is marked on the motor end cover. If the rotation is incorrect, swap the two wires going to the motor terminals, U1 and W1 as shown in paragraph 4.6 .

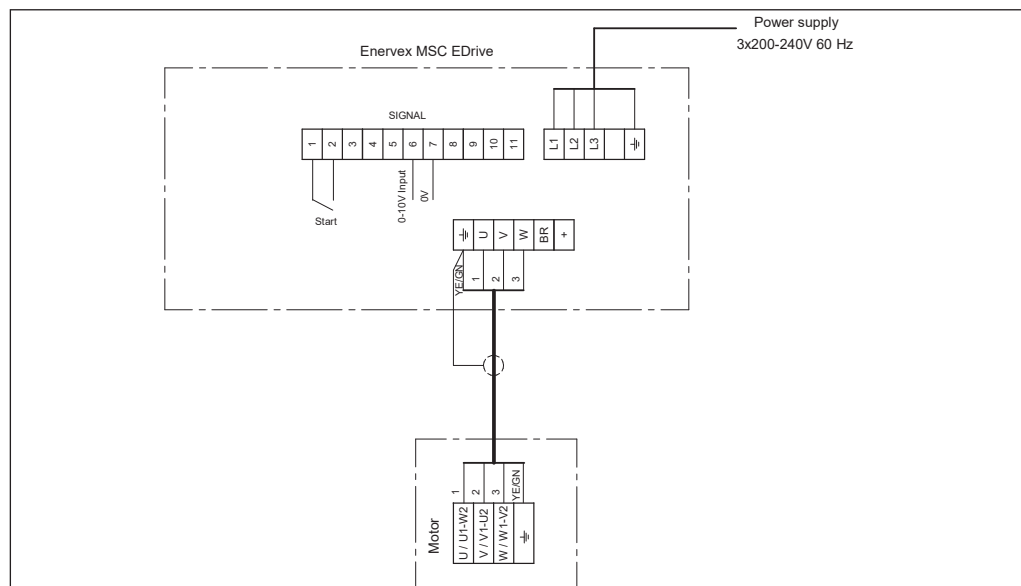

**Fig. 14**

#### 4.5 Installing a Proven Draft Switch

A safety system must be interlocked with the appliance to prevent flue gas spillage from the appliance and/or leakage through the fan or stack. The safety system should utilize a Proven Draft Switch (PDS-1) to ensure a negative pressure in the stack at all times. The device must be interlocked with the heating appliance(s) so it shuts down in case of insufficient draft, fan failure or power failure. Please refer to the PDS Installation Manual for wiring instructions.

If the installation includes for example an **exodraft** EBC12, EBC24, EBC30 or EBC31 Fan Control, a PDS-1 is not required as the function is integrated in the control.

For more information, please consult ENERVEX.

### 4.5 Installation of stack probe for PDS function

Install the probe for the Proven Draft Switch (PDS-1) in the vent connector. The probe must be located between the appliance and the power venter. The probe must be located at least 3 vent diameters downstream of the draft hood, draft diverter, or barometric damper. The probe placement should also observe distances from elbows and tees as shown in figure below. The tip of the probe MUST be flush with the inner chimney wall to get a proper pressure reading.

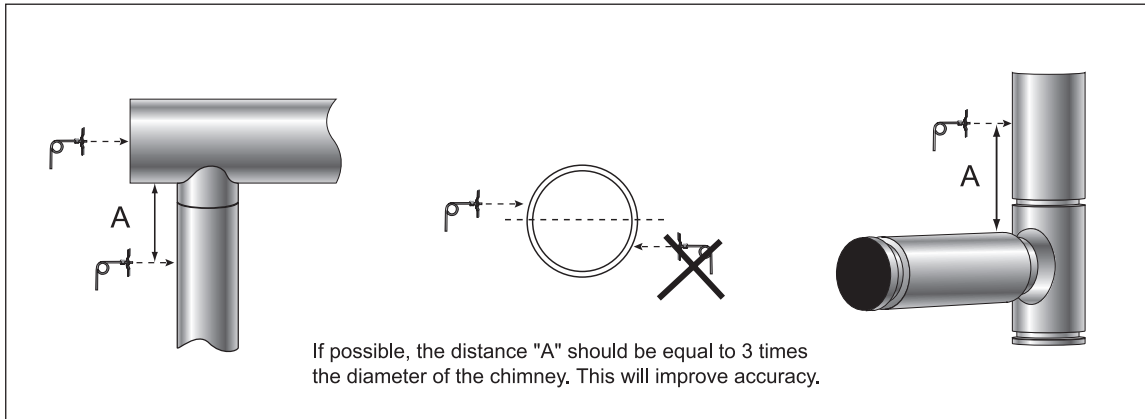

Fig. 15

### 4.6 Checking and changing rotation of IPVB 300, 350, 400, and 500

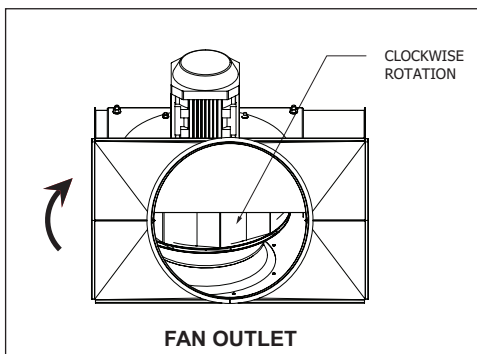

Fig. 16

To check the rotation of the impeller, it is necessary to be able to see the impeller or the rotation of the cooling vanes at the end of the motor housing. Looking through the outlet of the fan, the rotation of the impeller should be clockwise as shown in fig. 16.

Correct rotation direction is also indicated by an arrow on the motor end cover. There are holes in the end cover that allow you to see the cooling vanes, but it is difficult to see the rotation unless the fan is running very slowly.

It is possible for the fan to operate with improper rotation. However, the fan will only provide 25-30 % of full capacity. Improper rotation damages the motor, and causes various electrical faults at the Variable Frequency Drive. Fan rotation can be changed by swapping the two phase wires as shown on the wiring diagram in fig.17.

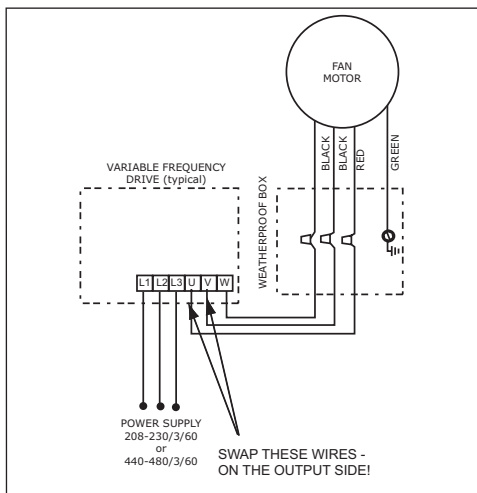

Fig. 17

**Danger**  
 Turn off electrical power before servicing. Contact with live electric components can cause shock or death.



## 5. Startup and configuration

### 5.1 General

The purpose of this **exodraft** IPVB fan is to ensure safe venting for a single appliance or multiple appliances. This can be performed via modulation, or through a single speed control where modulation is not required. This is accomplished by starting the power venter when the appliance calls for heat, and stopping the fan when the heat demand has been satisfied.

### 5.2 System testing

1. Check the line voltage with the motor name plate rating.
2. Determine if the impeller is running free, and has not be subjected to misalignment in shipping or during installation. Apply power, and check that the impeller is rotating in the direction of the arrow on the side of the fan housing. All **exodraft** fans run in a **clockwise** direction when viewed from the fan outlet or when looking down at the motor.
3. Switching any two phases between the fan and the power source (VFD is the power source if installed) will reverse rotation.

### 5.3 Adjusting fan speed

Start all heating appliances connected to the chimney with the fan installed.

1. If operating with fixed speed, set the variable frequency drive to the speed where no spillage is experienced anywhere in the system.
2. If operating with variable speed, a modulating control (**exodraft** EBC12, EBC24 EBC30 or EBC31) is required. Follow the instructions in the control's installation manual.

### 5.4 Testing safety system

Adjust the setting of the Proven Draft Switch or other device used.

Start the heating appliance and the fan, and make sure the safety device is functioning. Turn the fan off. Shortly after, the appliance should shut down.

## 6. Maintenance and troubleshooting

### 6.1 General

The **exodraft** power venter is designed for prolonged use, and no regular maintenance is required. It should be inspected periodically (at least once a year), and cleaned, if needed. This specifically applies in case it is being used with fuel oil. The power venter is designed to make this an easy task. The front part of the venter has the motor and impeller mounted on it, and it slides out to provide easy access.

The run capacitor is considered a wear part and will need to be replaced depending on usage.

### 6.2 Preparing the Power Venter for Cleaning

Referring to fig. 18 below, follow these steps to open the venter so it can be cleaned and inspected:

1. Remove the four hex nuts holding the motor mounting plate to the housing.
2. Motor and impeller assembly can be lifted out of the housing. See table listing weights for each model.
3. Clean the impeller and inside of the housing as needed.
4. Replace the motor and impeller assembly and tighten hex nuts to secure motor plate.

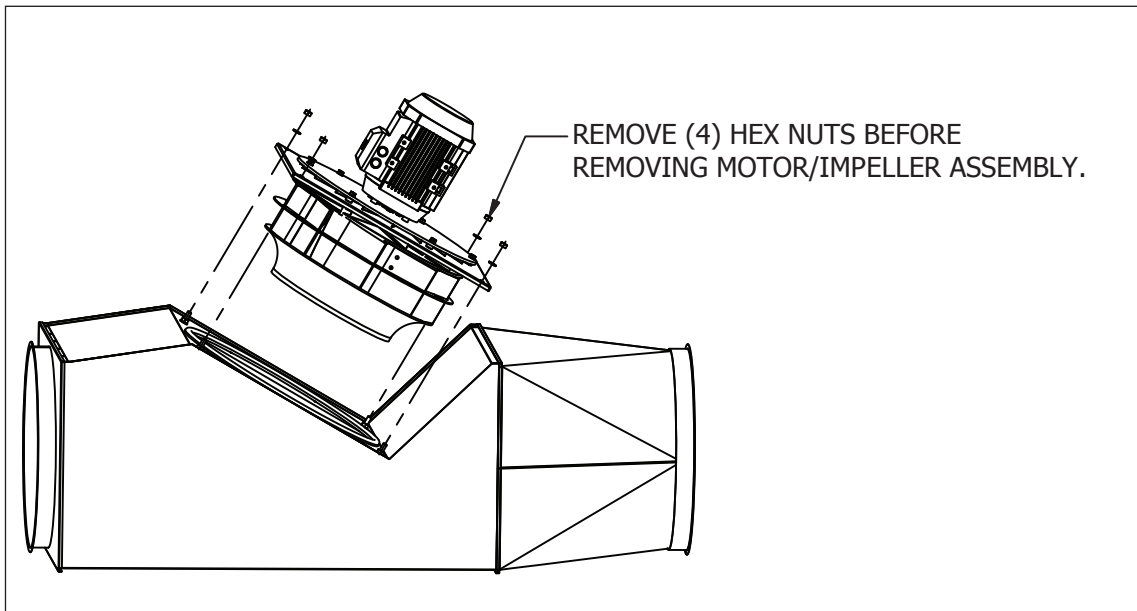

**Fig. 18**

#### NOTE

The approximate weights of the IPVB motor/impeller assemblies are as follows:

IPVB300: 40 lbs  
IPVB350: 50 lbs  
IPVB400: 70 lbs  
IPVB500: 105 lbs



#### Warning

**Do not open the housing unless power to the IPVB Power Venter has been disconnected from power supply.**

### 6.3 Troubleshooting

Problem	Possible Cause	Solution
<b>The fan is not operating</b>	– No power to the fan	– Check the power supply wires in the junction box by the fan. – Check the circuit breaker. – Check that the fan is actually turned on.
<b>The fan is rotating backwards</b>	Phase sequence in the power to the fan is reversed	– Swap two phases in the junction box.
<b>The fan is vibrating vigorously</b>	– Foreign matter is stuck in the impeller. – A ball bearing is damaged. – A balancing weight has fallen off impeller	– Remove the transportation device. – Turn off the fan and remove the foreign matter. – Turn the fan off. After the motor has stopped revolving, spin the impeller and listen for a grinding noise from the motor. If necessary, replace bearing or entire motor. – Re-balance impeller or replace it. Check motor for damages.
<b>The fan stops in the middle of firing cycle</b>	The motor is over-heating	Check the flue gas temperature at the fan inlet. The temperature should not exceed 575 °F (300 °C) during continuous operation. Call ENERVEX for advice.

Distributor in USA & Canada



ENERVEX Inc.  
1685 Bluegrass Lake Parkway  
Alpharetta, GA 30004

P: 770.587.3238  
F: 770.587.4731  
T: 800.255.2923  
info@energex.com  
www.energex.com

**exodraft**

3110093 IPVB300-500 EC US  
120170529